

POS_T - Successful Display of Tobacco Products

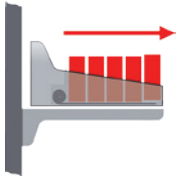



More power for success at the Point of Sale!

Successful presentation of products for brands and ranges

With forward-looking ideas, POS TUNING is constantly optimising the quality of products presentation at the Point of Sale.

The POS_T - Pushfeed

... with even better performance

NEW

- Progressive force development along the full pull-out length

- Improved efficiency = less force needed for filling, more force for the pushfeed

- Wider area of use for each feed variant – the new springs mean that more products are covered



... for more success at the Point of Sale!

The POS τ - Pushfeed

with even

... as well as the familiar quality features such as:

- springs made from high alloy stainless steel with progressive coil
- product-specific feed strengths
- the only pushfeed with  approval



... now offers even better performance in detail:

- **Progressive force development along the entire pull-out length of the spring:**
 - ... ➔ reliable function in all shelf depths and maximum product pressure from the first to the last packet!
- **Improved efficiency**
 - ... ➔ less force needed for filling, better care for products
 - ... ➔ more force pushing products forward
- **Wider area of use per feed**
the individual feeds cover a wider spectrum of product weights and sizes
 - ... ➔ simplified selection of the ideal feed strength during ordering and installation
 - ... ➔ greater efficiency in distribution and logistics

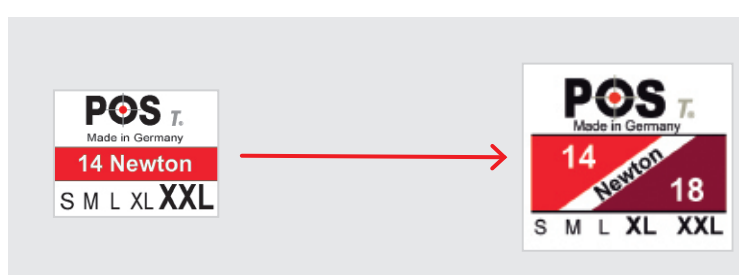
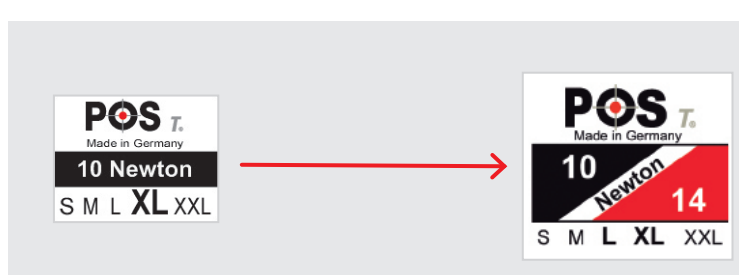
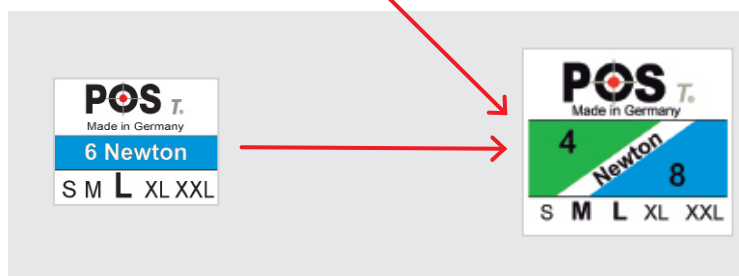
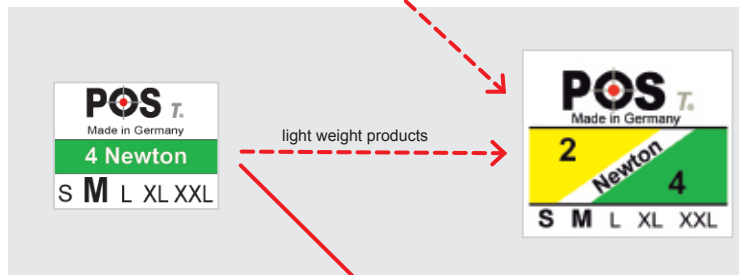
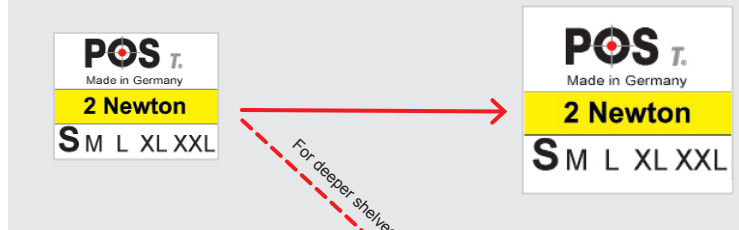
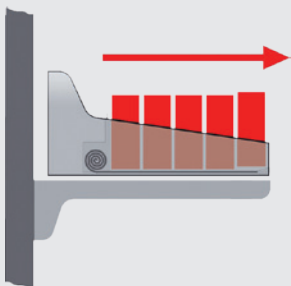

better performance

... for more success at the Point of Sale!



More ranges (examples):

- Tobacco products (cigarettes)
- Tobacco tins
- Cosmetics
- Tea
- ...



More ranges (examples):

- Cigarette cartons horizontal
- Deodorant (light)
- Condoms
- Chewing gum
- ...



More ranges (examples):

- Pudding mix
- Cigarette cartons vertical, cigarillos
- Small frozen boxes (light)
- Deodorant (heavy)
- ...



More ranges (examples):

- Napkins
- Large frozen boxes (heavy)
- Powdered soups
- Chocolates
- ...



More ranges (examples):

- Convenience products
- Wine gums
- Baking kits
- Tinned foods
- ...

Which pushfeed for which product?

The pushfeed performance required depends predominantly on the weight and product depth. In the table below, you will find a guide for the recommended feed performance where the weight and product depth meet.

	Product depth in cm								
	from 1 cm	from 1,5 cm	from 2 cm	from 3 cm	from 4 cm	from 5 cm	from 6 cm	from 8 cm	from 10 cm
from 1000 g							18	14	14
from 900 g						18	14		
from 800 g						18	14		
from 700 g					18	14			
from 600 g				18	14	14			
from 500 g			18	14	14	10			
from 400 g		18	14	14	10	8			
from 300 g		18	14	10	8	4			
from 250 g		14	10	8	4	4			
from 200 g	18	14	10	8	4	4			
from 150 g	14	10	8	4	4	4			
from 100 g	8	8	4	4	4	4			
from 75 g	8	4	4	4	4	4			
from 50 g	4	4	4	4	4	4			
from 40 g	4	4	4	4	4	4			
from 30 g	4	4	4	4	4	4			
from 25 g	2	2	2	2	2	2			

* For tobacco products (cigarette packs), use the familiar



If you have any questions about our new generation of springs, we would be happy to advise you!

- placement
- presentation
- showcase

...for more success at the Point of Sale!

Successful, Optimized Product Display

With today's display you cannot meet the requirements of tomorrow! This statement is emphasized by the recent advertising bans on cigarettes.

But one scenario stays constant....Decisions are made at the Point of Sale!

The proprietary brands industry, successful tobacconists, convenience stores and their shopfitters have come to rely on the knowledge and innovation provided by POS Tuning and the POS- τ display techniques.

The POS- τ systems allow you to increase impulse purchase whilst reducing stock handling operations in the store.

Philip Morris



Standard cigarette pack (OP)
 POS- τ Push feed 2 Newton, front W 39 x H 25 mm, with labelholder, Art. No. pvnx6802, Divider System F, height 60 mm Art. No. d06fc....



Cigarette Big Box and 100's
 POS- τ Push feed 2 Newton, front W 39 x H 25 mm, with labelholder, Art. No. pvnx6802, Divider System F, height 60 mm Art. No. d06fc....



Pouches, cigars, cartons
 POS- τ Push feed 6 Newton, front W 39 x H 35 mm, with Labelholder, Art. No. pvpc6502 and guide profile Art.-No. f3xcl..., Divider System F, height 60 mm Art. No. d06fc....

All information concerning this product is available in our parts list "POS- τ Pusher System", "POS- τ Shelf Management Systems" - "POS- τ Functional elements for the presentation of tobacco"

Products are always displayed at the front of the shelf in full view and easily accessible

The POS-7 push feed is a technical device which after the removal of a product from the shelf automatically pushes the remaining products to the front by means of spring force.

Depending on its specification the POS-7 Push feed has a power from 2 to 14 Newtons. Accordingly, it is suitable for use for both light and heavy products.

Even after the last product is purchased from the shelf the push feed remains in an upright position (with label) signposting the regular place for your product.

The progressively wound spring provides maximum power when the shelf is full and a lesser force as the shelf empties. The push feed exerts a slight counterpressure enabling easy re-stocking of the shelf and re-placement of unsold products.

Service Life

The stainless steel spring can be compared to the recuperating spring within the safety belt of a car and it has a corresponding service life. Therefore after 20,000 pull out operations or 10 years service you can still expect a full operating capacity from the spring.

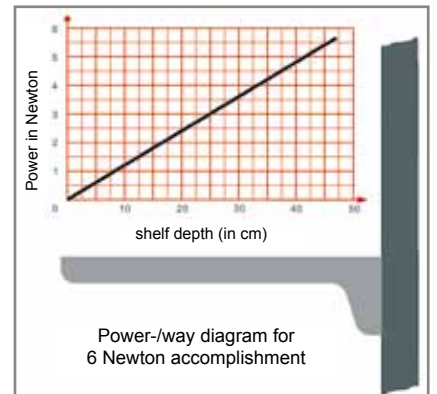

4 Steps to Shelf Automation

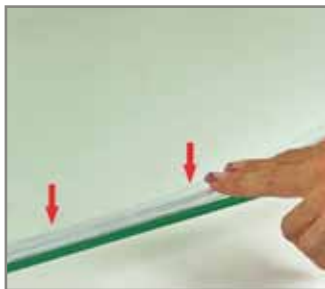

Fit or glue the adapter T-rail onto the shelf.



Clip POS-7 push feeds and compartment dividers on adapter T-rail.



Fit label holder and label according to plan, if required.



Place products on shelf.

This system can be used for all existing or new fittings.

Display a Wide Variety of Types and Brands!

Due to the ability to present all of the shelves in a horizontal format, the POS-7 Push Feed system allows you to save up to 80% of the available shelf surface. The use of glass shelves allows for small interspaces between the shelves (min. 128 mm clearance required) and consequently optimizes the use of the available space.

Utilising the POS-7 Push Feed system all products/facings are positioned within your customers optimal viewing angle.

This provides clarity and encourages impulse purchases!

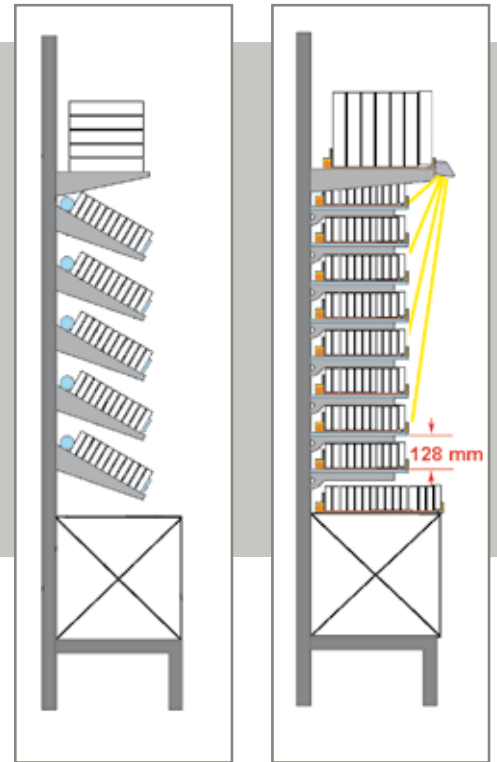

JTI Gantry



Using the modular POS- τ Shelf Management system with Product Pusher you can realize innovative, detailed solutions for all products

RMC

- Mobile compartment dividers and pushers make adaptations to existing assortments and new product family creation easier.
- The transparent low front offers unhindered sight to the facing.

POS- τ Push feed with 2 Newton and front W 39 x H 25 mm, with label holder, Art. No. pvn6802, for OP and Big Box, Divider System F, height 60 mm Art. No. d06fc....



- Lifting of the front packet eases removal.
- Restocking can be carried out with one hand.

POS- τ Push feed with 2 Newton and front W 39 x H 25 mm, with label holder, Art. No. pvn6802, for OP and Big Box, Divider System F, height 60 mm Art.d06fc....



Optimal use of the available space even when displaying narrow products.

e. g. POS- τ Push feed System "Mini" W 19 mm for ten packs or cigarette paper.

POS- τ Push feed 2 Newton, width 19 mm, Art. No. pnnx3800, with guide profile Art. No. f1xcl.... Divider System F, height 60 mm Art.d06fc....

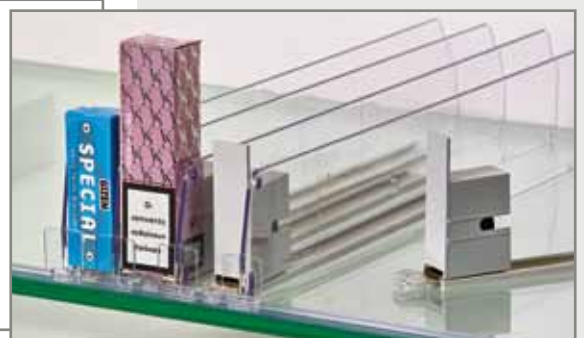

Ensure the ideal front presentation of flat and narrow packs up to a depth of 8 mm.

e. g. POS- τ Push feed W 28 mm with label holder „Slims-Adapter“ (clamping range Slims to front 8 mm) for ten packs, Slims or cigarette paper.

POS- τ Push feed 2 Newton, front 20 x 25 mm, width 28 mm and Slims-Adapter W 32 x T 18 mm, Art. No. panx6711 Divider System F, height 60 mm Art.d06fc....



Using the modular POS-*T* Shelf Management system with Product Pusher you can detailed solutions for all products

OTP



Pouches -

Secure position with 35mm high front

greater stability for tall products by using the extension for the Front Anchor Art. No. 10027 (s. page 9 below „front label holder“)

*POS-T Push feed with 6 Newton and front height 35 mm, with label holder, Art. No. pvpc6502, guide profile Art. No. f3xcl...
Divider System F, height 60 mm Art. No. d06fc....*



Tins

POS-*T* Push feed and guide profile and divider with strengthened rear clamping.

*POS-T Push feed 2 Newton and front 25 mm, with label holder, Art. No. pvnx6802, guide profile Art. No. f3xcl...
Divider System F, height 60 mm, with strengthened rear clamping and Adapter T rail Art. No. a01s.... for rear clamping*



Cigars

for smaller products POS-*T* Push feed W 28 and broadened label holder.

*POS-T Push feed W 40 with 6 Newton and front height 35 mm, with label holder, Art. No. pvpc6502.
For smaller products POS-T Push feed W 28 with 2 Newton, Front H 25 mm Art. No. papc6700 and broadened label holder Art. No. e36t0065, guide profile Art. No. f3xcl... and divider System F, height 60 mm*



Cigar tubes

POS-*T* Display unit for small articles

POS-T Tiny Presenter Art. No. 10560, W 300 x D 220 x H 120 mm, with 8 compartments W 24 mm and 2 compartments W 32 mm, POS-T Push feed System Mini, 2 Newton Art. No. pnnx3800

realize innovative,

Cartons

Vertical display

to optimize the available presentation space.

“Cigarette boxes” are displayed in a vertical position on the uppermost shelf, ready to hand and encouraging impulse purchases. Thus you can present 9 different facings on one meter shelf.

POS-T Push feed with 6 Newton, Front H 35 mm, Art. No. pvpc6500 and guide profile Art. No. f3xcl..., divider System F, height 60 mm



Horizontal presentation

To display “big boxes” we recommend a horizontal presentation of 2 stacked boxes, standing on 2 guide profiles with 2 push feeds 6 Newton. Brackets with a 5° ascent achieve additional stability against overturning and improve visibility.

2 x POS-T Push feed 6 Newton Art. No. pvpc6505, with label holder Art. 10079, 75 x 130 mm, guide profile Art. No. f3xcl..., divider System F, height 120 mm Art. No. d12fc....



Reemtsma „Bestseller“



Accessories



Cigarette Stock

Effective stock control tool for tobacco products. The graduated ruler is positioned at the rear pack - this enables you to read the existing stock.

Tip: The advertising gift for the trade!

POS-T Cigarette Stock Art. 50005



“Out-of-Stock Indicator” for label holder

This is visible when only 3 packs are left, indicating that this compartment must be restocked.

Out of Stock Indicator compatible with label holder W 49 Art. No. 10081, suitable for products with a max. depth of 57 mm, W 40 Art. No. 10082 for products up to a width of 47 mm and W 75 Art. No. 10083 for products up to a width of 91 mm.

BAT Connect



All information concerning this product is available in our parts list “POS- τ Pusher System”, „Accessories für Pusher“, “POS- τ Shelf Management Systems” - “POS- τ Functional elements for the presentation of tobacco”

POS-7 Usual front place reservation -

Always in the right place - Consumer's Behavior and Product Awareness

Place Reservation

Label holder and Brand label guarantee the exact realization of the planogram at the point of sale, easy restocking and shelf care whilst also helping to avoid the loss of usual place reservation.

Brand labels sorted according to your planograms can be supplied as complete label sets.

Important: The Brand labels remain vertical even when the shelf is empty for easy identification of usual place reservation.

Individual Label Sets

Individual label sets are available and can be supplied in an assortment according to your special instructions.

Tobacco Label set

Set with 366 single labels, for all current cigarette and tobacco brands.

Art. No. 84402 Label set, 49 x 80 mm, suitable for Label holder Art. No. e49t0080.

Label holder

The label holders are compatible with all POS-7 Push feeds which are available on the market. We offer label holders in different standard sizes which have been adapted to the product dimensions:

Art. No. e30t0065 - for label size 30 x 65 mm

Art. No. e36t0065 - broadened label holder
for label size 36 x 65 mm

Art. No. e40t0080 - for label size 40 x 80 mm

Art. No. e49t0080 - for label size 49 x 80 mm

Art. No. e75t0130 - for label size 75 x 130 mm

Front label holder and Price label holder

for mounting on the front of POS-7 Push feed

Art. No. 10027 - Information holder
for label size 38 x 42 mm

Art. No. 12431 - Price label holder
for label size 42 x 20 mm



Shelves

POS-T Glass complete shelves



To retrofit and optimize existing shop fittings economically dealers have used our Glass-Complete-Shelves or our equipment sets on existing product shelves to successfully present tobacco products with excellent results.

We offer a solution for every shelf width and every shop fitting system.

This allows our customers to achieve a top presentation with up to 80% more storage space without lots of reconstruction, while giving the entire sales display just that bit more than an added „facelift“.

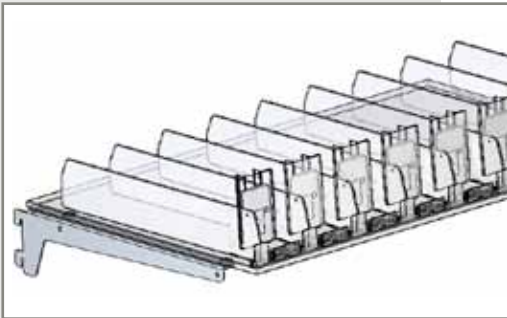

Equipment for Glass-Complete-Shelves

Glass shelf, depth 380 mm, punched hole spacing as specified, incl. push feed system „F“ with label holder and divider 355 x 60 mm

Hole spacing in mm

• 30 • 32 • 35 • 40-42 • 45
• 50 • 60 • 70 • other

Width mm	Number of Facings	Push feeds		Art. No.
		2 N	6 N	
600	10	7	3	50046
650	11	8	3	50047
900	13	9	4	50049
1000	15	11	4	50040
1250	19	13	6	50042

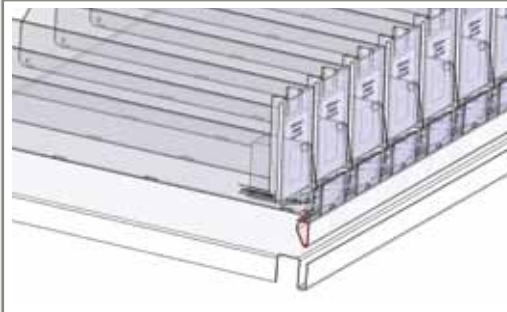

Equipment for tobacco product shelves in metal

With front U-profile, compatible with most shelving systems with adapter T-profile, with push feed system „F“ incl. labelholder and divider 355 x 60 mm, **without** bottom, **without** consoles

Width mm	Number of Facings	push feeds		Art. No.
		2 N	6 N	
600	10	7	3	50056
650	11	8	3	50057
900	13	9	4	50059
1000	15	11	4	50050
1250	19	13	6	50052

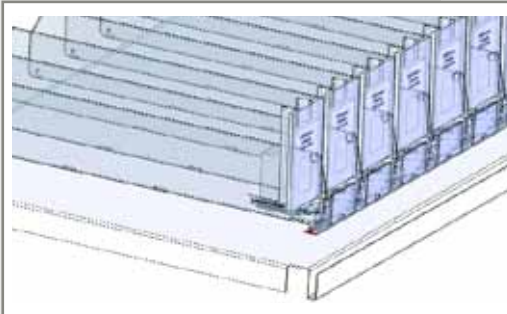

Same as above, however with self-adhesive adapter rails

Width mm	Number of Facings	push feeds		Art. No.
		2 N	6 N	
600	10	7	3	50066
650	11	8	3	50067
900	13	9	4	50069
1000	15	11	4	50060
1250	19	13	6	50062



Art. No. 21557 Board fastening wedges

Required at the end of the shelf when the punched holes are wider than 8 mm (except a hole spacing of 50 mm Tegometall) - available in sets of 10

Art. Nr. 84402 Standard label set for tobacco products

see page 9

Accessories

POS- τ Matic Shelf with FiFo-Function

The shelf is constructed using a light metal frame featuring Guide Profile/Runners to the sides whilst the front and rear rails provide support for the Push Feed and Divider system

A separate retention bar is fitted to aid the “pull out” function

- modular design
- available in depths 280, 305, 330 and 355 mm widths up to max 1.000 mm
- plastic slip-in guides to be inserted into lateral wood panels.

According to the product weight and dimension

- 1 FiFo-guide profile, 1 POS- τ Push feed and 1 mobile plastic compartment divider

is used per facing.

Function:

For restocking purposes the POS- τ Matic shelf is pulled out and fixed, this action disengages the push feeds.

The compartment is now accessible and can be restocked by placing the new products directly behind the remaining stock.

After restocking the POS- τ Matic shelf is pushed back into place engaging the push feeds thus ensuring that the products are pushed to the front of shelf as each product is removed.

This style of restocking perfectly supports the FiFo principle.



POS- τ Matic-Shelf with FiFo-Function, made of light metal, naturally anodized, with plastic drawer rails, retaining system, POS- τ Push feed 2 Newton with label holder, with dividers H 60 mm

Width	effective width	Depth	Number of Facings	Art. No.
600	581	371	9	50230
650	631	371	10	50231
900	881	371	14	50232
1000	981	371	15	50233

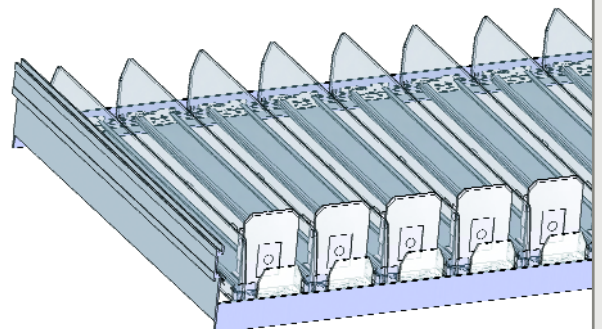

Customized design possible following specification for facings, structural width and depth.

Counter Solutions

POS- τ QuickServer



Your counter provides the pivot

Use your counter as a communication tool, the pivotal point of sale that is accessed by every customer who makes a transaction!

It is the point of sale for impulse buying and a working place where many hours are spent.

POS- τ QuickServer

Fundamentally a sales display unit for cigarettes, consisting of an aluminium frame and acrylic product shafts. This unit can be installed beneath the counter, in front of a door or even a back panel.

Easy restocking is guaranteed by the removable product shafts. The acrylic shafts can be supplied in three different versions, of which each is suitable for 20 packs King Size, 100 mm cigarettes and larger packs. The shafts are equipped with a POS- τ Lift which continuously pushes the goods upwards.

This example shows the Quick Server-Product Stacks built into the countertop.

Advantages:

- The top brands are constantly accessible to the seller
- Less rotary motions
- Permanent eye contact with the customer and the shop
- Lower theft rate
- Improved ergonomics for the salesman



Art. No. 10518

POS- τ Pusher Drawer W 540 x D 434 x H 110 mm

is the alternative for an easy sale of fast moving goods which are directly accessible to the salesman.

The metal drawer, extendible by 6 cm, has 8 compartments with 4 Newton POS- τ Push feeds.

On request the pushing capacity can be increased to 6 or 10 Newton for goods with a higher specific weight.

POS-T Overhead Display unit

POS-T Overhead Display unit

Continuous display of products in a way to ensure optimal visibility and accessibility.

The overhead display unit is a modular sales display unit for cigarettes positioned above the counter.

It consists of transparent shelves 970 x 450 x 75 mm with silver-coloured high-tech consoles and 15 variable compartment dividers, each made from plastic.

To ensure easy withdrawal the lowermost pack is pushed upwards. You can fit up to three shelves on top of each other.

Offering you the desired advantage for your products at the Point of Sale!

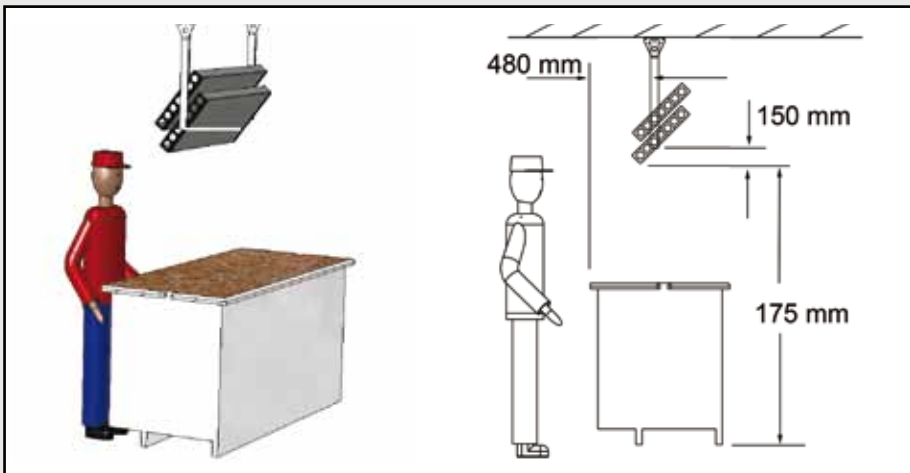

Art. 07181

POS-T Overhead Display Unit with Slide-Light Front A2

(W 635 x D 150 x H 450 mm)

a total of 10 compartments, of which each is suitable for up to 20 cigarette packs, ensuring the last pack is pushed upwards for easy removal. The compartment widths can be easily adjusted, e. g. for bigger packs.

The Perspex advertising front is compatible for A2 slides in formats of up to 608 x 436 mm. Again lighting is complete with two energy-saving built-in lamps each of 16 Watt, electronic fluorescent lamp ballasts, 1500 mm supply line complete with plug. All housed in a sturdy silver-coloured plastic carcass, fitted with comfortable hinged light metal profiles for easy slide change.



Shelf Lighting + Advertising

POS-T Light / POS-T Brandline

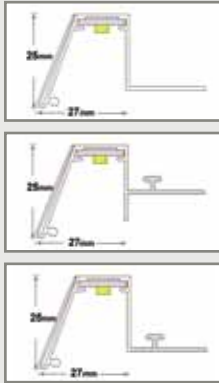

POS-T Brandline

POS-T Brandline shelf lighting is extremely slim and enables brands or product segments to be singled out on the shelf without inhibiting product visibility.

Translucent promotional or information strips are inserted into the clear front. Integrated LED's create an atmospheric backlight.



The LED lighting elements are positioned in front of the shelf to highlight the front facings of the products below the shelf.

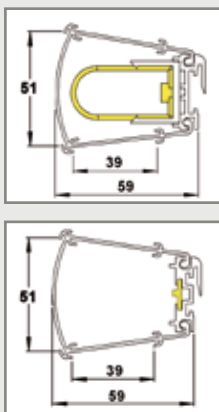

POS-T Light

POS-T Light is the distinctive front of shelf illumination system to highlight brands and assortments.

Available with T5-Lights and LED-Lights.

POS-T Light is compatible with all shop fitting systems and is installed in front of the shelf. The POS-T Light can be equipped with colour filters for special lighting effects.

Promotional slide inserts in the UV resistant lighting covers convey emotional messages and brand images to the shopper.



All information concerning this product is available in our brochure and parts list "POS-T Lighting"

Effect Lighting

POS-7 Magic Divider



Magic Divider

Novelties or premium products deserve special attention. The shelf divider lighting „POS-7 Magic Divider“ attracts the shopper’s attention as if by magic, ensuring that your “star” is not lost amidst the assortment.

Colour effects are added by inserting translucent strips.



Illuminated Promotional Slides

POS-7 Slide Light

Art. No. 07180

Slide-Light A2

W 635 x D 150 x H 450 mm

Labelling a product line or promoting a brand - the light-weight POS-7 Slide Light (weight < 2 kg) can easily be installed on plain surfaces. In an upright or inclined position with additional fittings the Slide Lights can be mounted onto the back panels of almost all shelving systems.

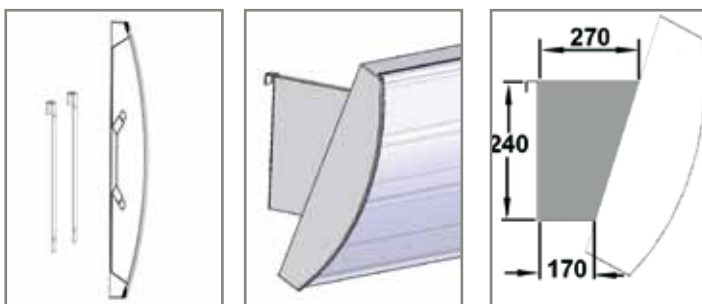

Theft Prevention at the Point of Sale

POS-T Anti-Theft-Systems

The majority of high risk goods are not openly presented any longer, which results in a significant decrease of sales.

POS-T Anti-Theft Systems allow products with high theft rates to be displayed openly ensuring ease of access for the customer.

The result: steady sales and a reduction of shoplifting rates of up to 90 %!

Examples



The POS-T Counter

The Counter calculates the products in a shelf position and signals any inventory changes indicating the point of time and quantity, to the alarm transmitter.

The POS-T Counter offers further applications such as permanent inventory, as well as improving the availability of products by sending a notification when the minimum stock level of a shelf has been reached.



The POS-T Optical Gate

The Optical Gate is a light barrier for installation to the divider front POS-T System F.

This inconspicuous technology is especially suited to the protection of high value product ranges.



The POS-T Mechanical Gate

The Mechanical Gate is a plexiglass cabinet with a hinged flap door. It can be easily installed on all customary shelves to prevent theft in 2 ways:

- Product inside the cabinet can only be accessed by using both hands as the flap door needs to be kept open. Therefore a sweeping of the whole shelf by a potential shoplifter is nearly impossible
- Opening the flap door triggers a voice message, e.g. "sales of tobacco to people under the age of 18 are illegal." which limits the anonymity of potential shoplifters.

Individual Solutions

The POS-T Toolbox

Individual Solutions

The POS-T “Toolbox” of proven standard components provides a solid and efficient platform.



The toolbox combined with our creative resource offers you the desired advantage for your products at the Point of Sale!

Frame Presentation

Customised frames, designed for your products.



Accentuated

Front-Pack-Holder
- designed to present the product to you



Inclined Presentation

- Distraction – provides a focal point for the eye



Individual Solutions

The POS-T Toolbox

“Primus inter pares”

(first choice amongst others)

- how to present *your* Product
in focus of the consumer

*... for more success at the
Point of Sale*



Framed

- an eye catcher for your products



Double-Decker Cassette

- Creating more impact-building
brand communication



Special

Customized tray for one facing
including pusher
- front with brand label



Bespoke Solutions

...for enhancing your success at the Point of Sale

Sales displays and incremental product placement establish a criteria for additional turn-over and successful product launches.



Scandinavian Tobacco Counter Display
with POS-T Push feed



Gizeh Display
acrylic tray with POS-T Push feed
and Dividers
(front with brand label)

Among the relevance of displays, the **quality of the product presentation** has a decisive impact.



Independence Display
equipped with POS-T Push feed
(made of cardboard
by WT-Displays GmbH)



Moods Display
equipped with
POS-T Push feed
(made of cardboard
by Bittner GmbH)

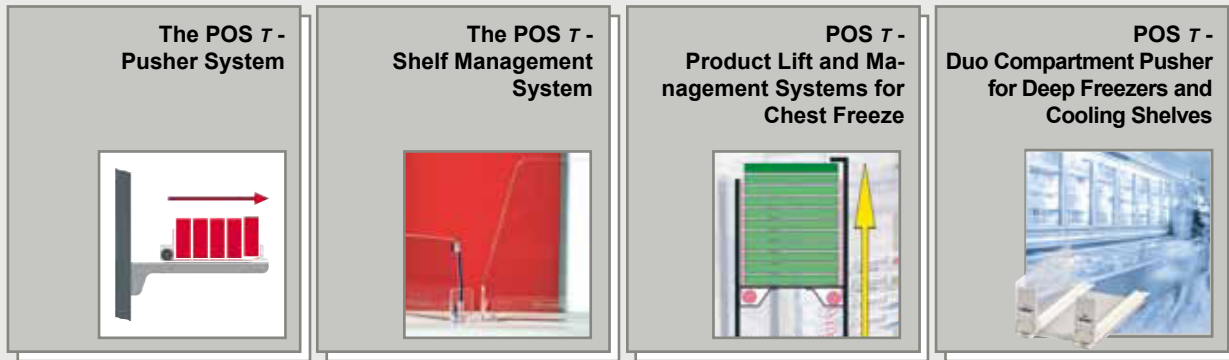

• placement

• presentation

• showcase

... for more success at the Point of Sale

